

**Development of an Infrared Spectral Library of  
Pigments used in Ancient Art**

by

Jennifer L. Taylor

Dr. Patricia Lang

*Patricia L. Lang*  
(Advisor)

Ball State University

Muncie, Indiana

April 27, 1994

Graduation: May 1994

SpCo  
Treas

LD

2489

.24

1994

.T39

## Purpose of Thesis:

This thesis outlines my research performed under Dr. Patricia Lang in the Chemistry Department. The research involved using infrared spectroscopy to evaluate several pigments samples supplied by Getty Museum. The spectra obtained can be found in the Infrared Spectral Library of Artist and Artisian Materials.

Acknowledgement:

I wish to give a special thanks to Dr. Patricia Lang in her assistance with my undergraduate research. I could not have asked for a better person to work with this past year. I will miss my time spent with Dr. Lang in class and in my research. You taught me well, and I hope you can be proud of my accomplishments.

## I. Purpose of Research

The purpose of my research was to assist in the development of an infrared spectral library of artist materials. At the time that I received my materials, Ball State University was one of twenty-three organizations consisting of universities, museums, institutes, and labs which were assisting in the compilation of art material's infrared spectrum. The coordinator of the overall project was the Getty Museum.

The infrared spectrum of a material can give specialists a "fingerprint" of the sample and contains information concerning its nature and chemical composition. Such chemical knowledge of the art material facilitates the art historians interpretation of the artistic process and, more practically, can be used for restoration purposes. This knowledge will also allow the art museums to keep their ancient artwork on display under conditions conducive to their preservation. A comprehensive spectral library of known, well-characterized reference materials that were available to ancient artists would be an invaluable and necessary tool with which to compare an infrared spectra of an unknown material.

## II. Experimental

The pigments received were all natural pigments found in plant and animal matter. The following is a collective list of pigments involved in my research:

Red Jasper	Safflower
Alkanna Roots	Lady's-mantle (cut pieces)
Rathania Roots	Henna (black powder)
Goldenrod (cut pieces)	Catechu (powder)
Irish Moss	Frangulae Cortex (cut pieces)
Malachite (natural, standard)	Chrysocolla
Pinkcolor (good quality)	French Ochre
Cassel Brown (water soluble, for staining wood)	

Each reference pigment was prepared in a similar manner. This manner was replicated from what real samples from historic artwork would be prepared. Samples were of a microscopic proportion, generally, approximately twenty microns by twenty microns in dimension. Under stereoscopic examination, samples were rolled into a thin pellet to allow

as much light as possible to pass through. The sample was then placed on a salt plate and placed under an infrared microscope. The sample spectrum was obtained at four  $\text{cm}^{-1}$  resolution and fifty signal-averaged scans and then ratioed to a background obtained from a clean salt plate. This process was done several times for each sample to ensure that a representative infrared spectrum was obtained. The instrument used was a Perkin-Elmer 1760-x Fourier transform infrared spectrometer coupled to a Spectra-Tech IR Plan microscope.

### III. Infrared Microscopy

There are a few points of central importance when trying to be successful in using a microscope with infrared according to Katon, Sommer, and Lang. One can not simply couple an optical microscope to an infrared spectrometer because glass optics of typical microscopes do not transmit radiation in the mid-infrared range. Also, one must realize the sample is truly part of the optical system. Sample size, shape, thickness, and refractive index need to be considered. Finally, sample pathlength is important. A good pathlength for pure solid is generally less than  $10\mu\text{m}$ .

According to Katon, Sommer, and Lang, an infrared microscope must be able to perform three basic functions. First, it must focus or condense infrared radiation onto the sample. Second, radiation transmitted or reflected by the sample must be collected and imaged onto a detector. Detectors are usually liquid nitrogen cooled mercury-cadmium-telluride (MCT) quantum detectors. Third, The microscope must allow the user to view and select specific areas of the sample at high magnifications.

The infrared microscope is composed of four basic parts: a condenser, an objective, an area-defining aperture, and a visible viewing system. In most commercial infrared microscopes, the condenser is an off-axis paraboloid or ellipsoidal mirror shown Figure 1 (Katon, 184). The off-axis element creates a larger beam diameter at the sample focus than

earlier models. The objectives used today are Cassegrains of the Schwarzschild type. Apertures are used to “physically make (define) or stop down the image of the sample formed by the objective. Placing an aperture at any place other than an image plane would not limit the image size and would reduce the intensity of the sample image with a concomitant reduction in the signal-to-noise ratio of the measurement” (Katon, 183). One other thing to consider is a good purge system over the entire optical path of the microscope and spectrometer is needed if high quality results are desired.

*“The obvious advantage of microspectroscopy is that it provides us with the capability of obtaining selective, molecular information on microscopic-sized particles in a relatively simple fashion” (Katon, 203).*

#### IV. Results/Conclusions

A representative spectrum of each pigment studied is shown in Figures 2-16. These spectra will be included in the Infrared Spectral Library of Artist and Artisan Materials.

Several well-known organizations have made large contributions to the spectral collection at this point in time. The following is the list given as of March 1994:

- Federal University, Minas Gerais, Brazil
- Getty Conservation Institute
- Harvard Fine Arts Museum, Boston
- Loyola Marymount University, Los Angeles
- M.H. deYoung Memorial Museum, San Francisco
- Museum of Modern Art, New York
- National Gallery of Art, Washington
- Philadelphia Museum of Art
- Ball State University
- Courtauld Institute of Art, England
- Miami University, Ohio
- National Archives & Records, Washington D.C.
- National Committee of Research, Italy
- Tate Gallery, London
- University of Florence, Italy
- Winterthur Museum, Delaware

Of the spectra received by the Getty Museum, the following is the breakdown of the types of art related materials sampled by these contributors:

- Proteins
- Waxes
- Oils
- Gums
- Synthetic Resins
- Natural Resins
- Dyes
- Pigments

For the contributors of the spectrum, another benefit will occur. Once the compilation of all spectra is complete, each contributor will receive his own copy of all spectra available. The Getty Museum is also considering a type of conference to give information about the spectra available and how people acquired them.

V. Bibliography

Katon, J.E., A.J. Sommer, and Patricia L. Lang. "Infrared Microscopy."

Applied Spectroscopy Reviews 25(3&4) (1989-90): 173-211.

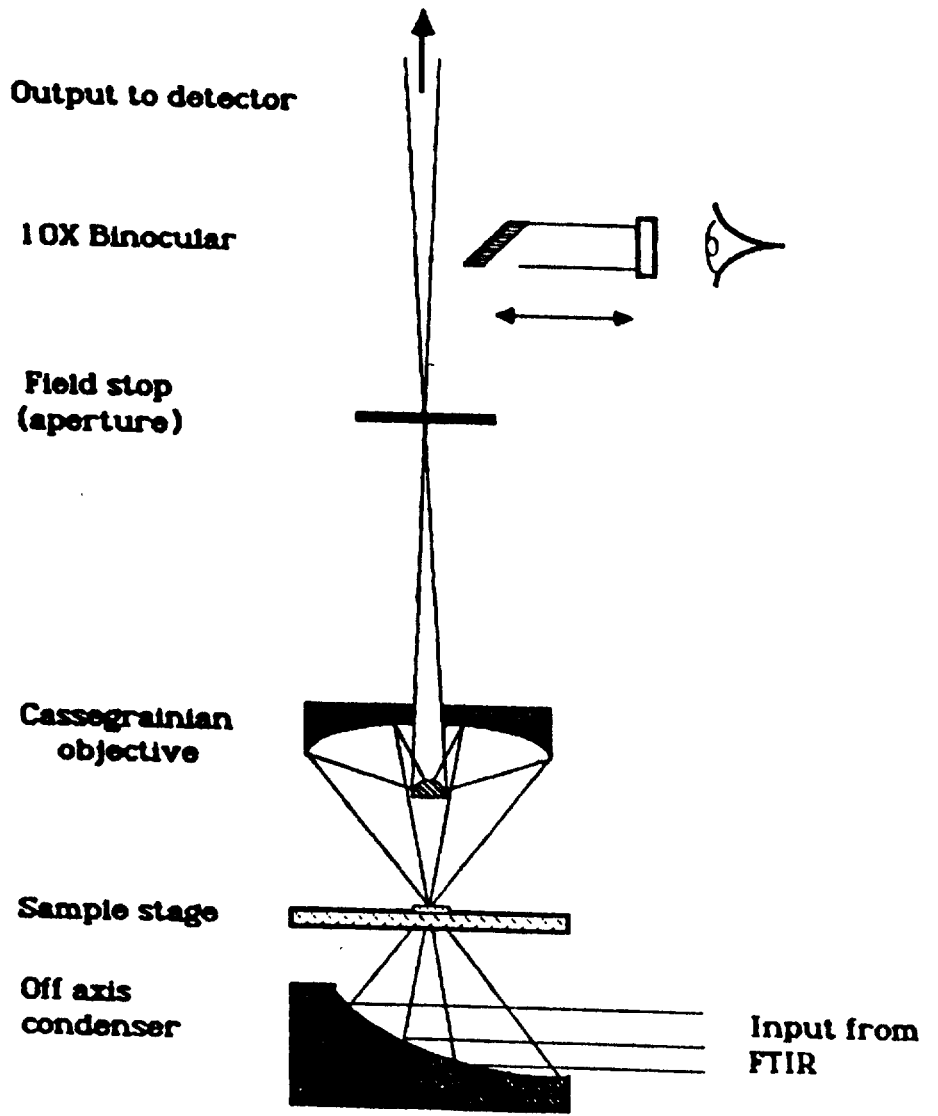

**FIGURE**

**1**

French Ochre Fig 2

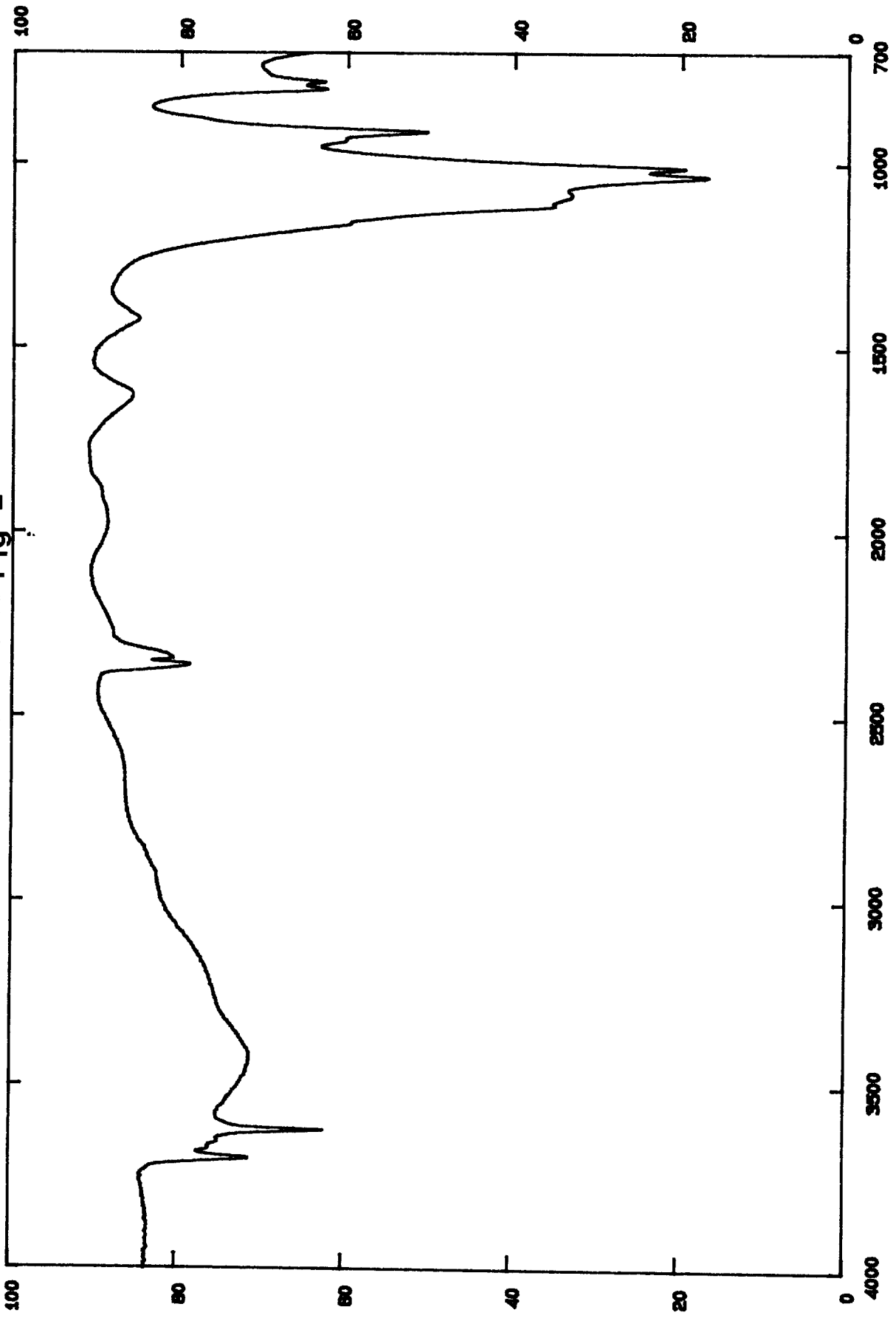

Pinkcolor (good quality) Fig 3

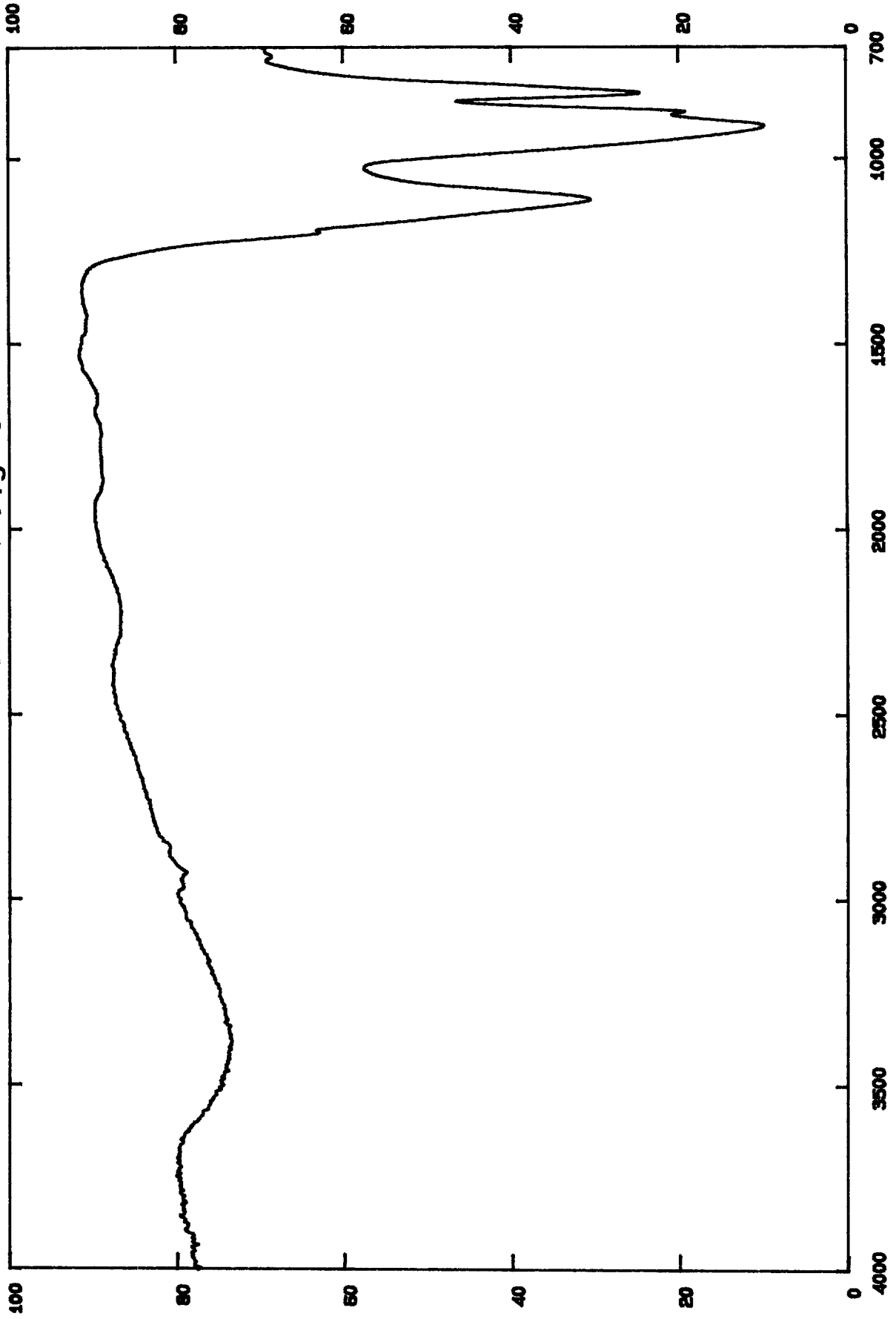

Chrysocolla Fig 4

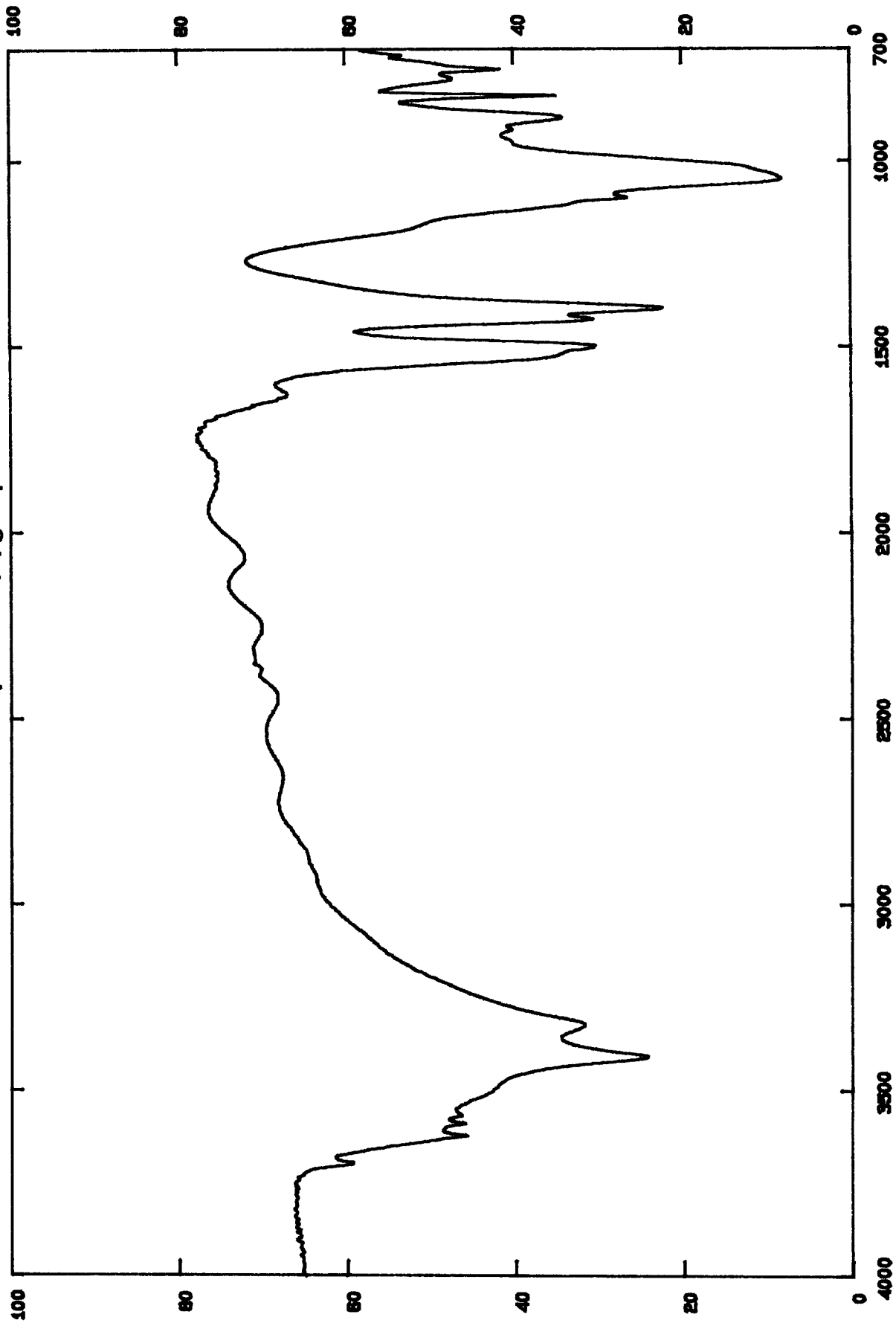

Malachite (natural, standard) Fig 5

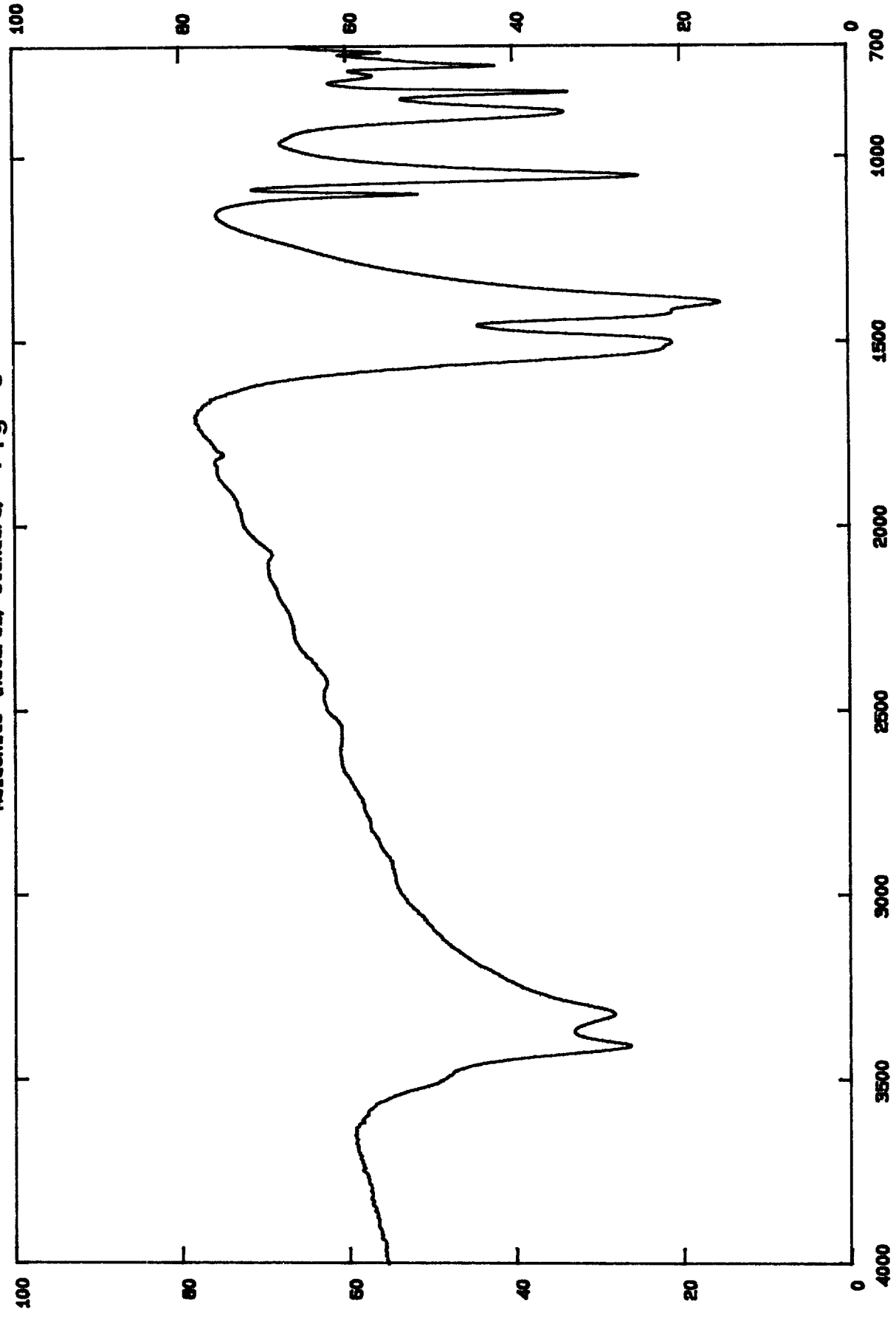

Alkanna Roots Fig 6

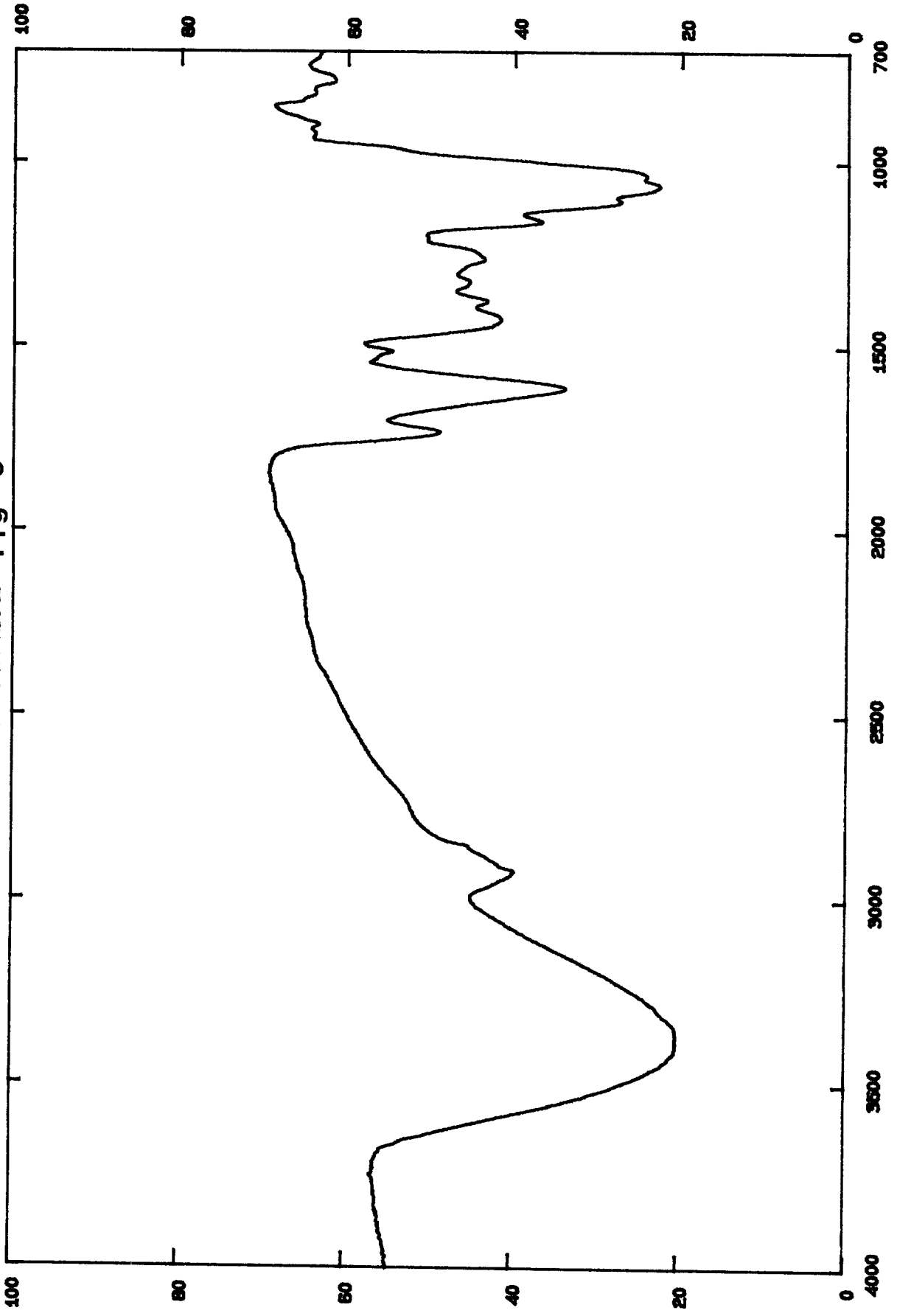

Rathenle Roots Fig 7

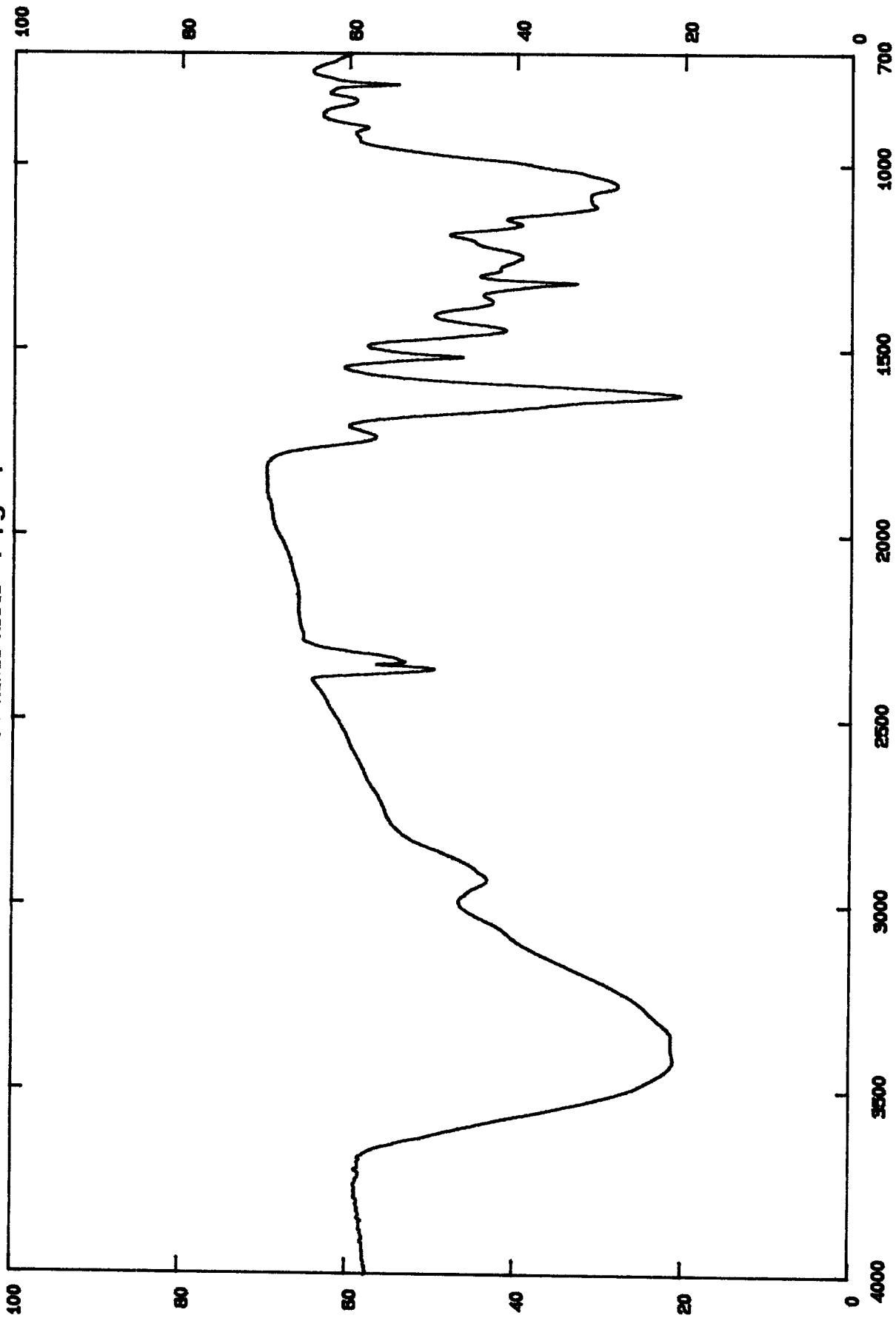

Safflower Fig 8

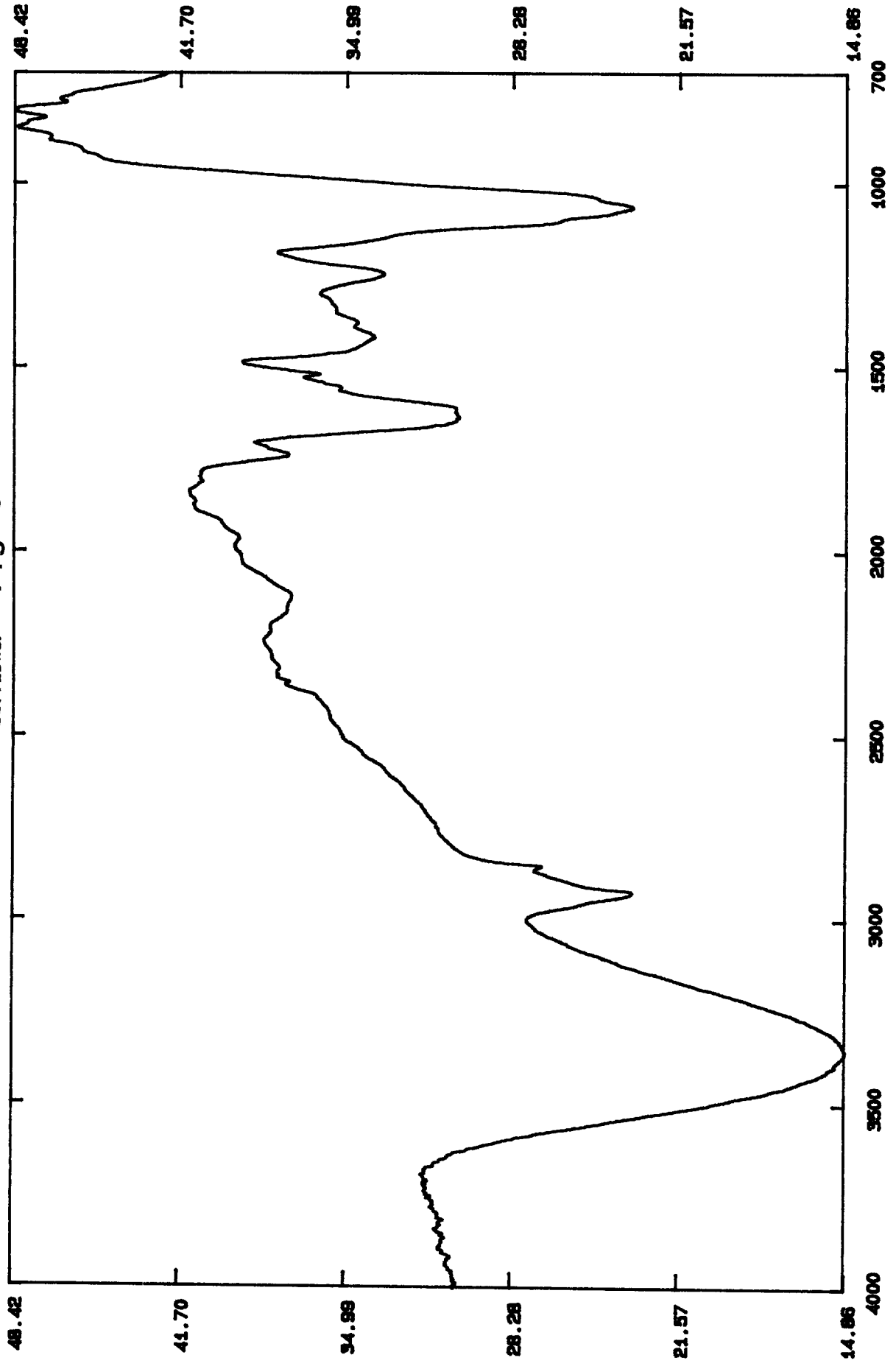

Lady's Mantle Fig 9

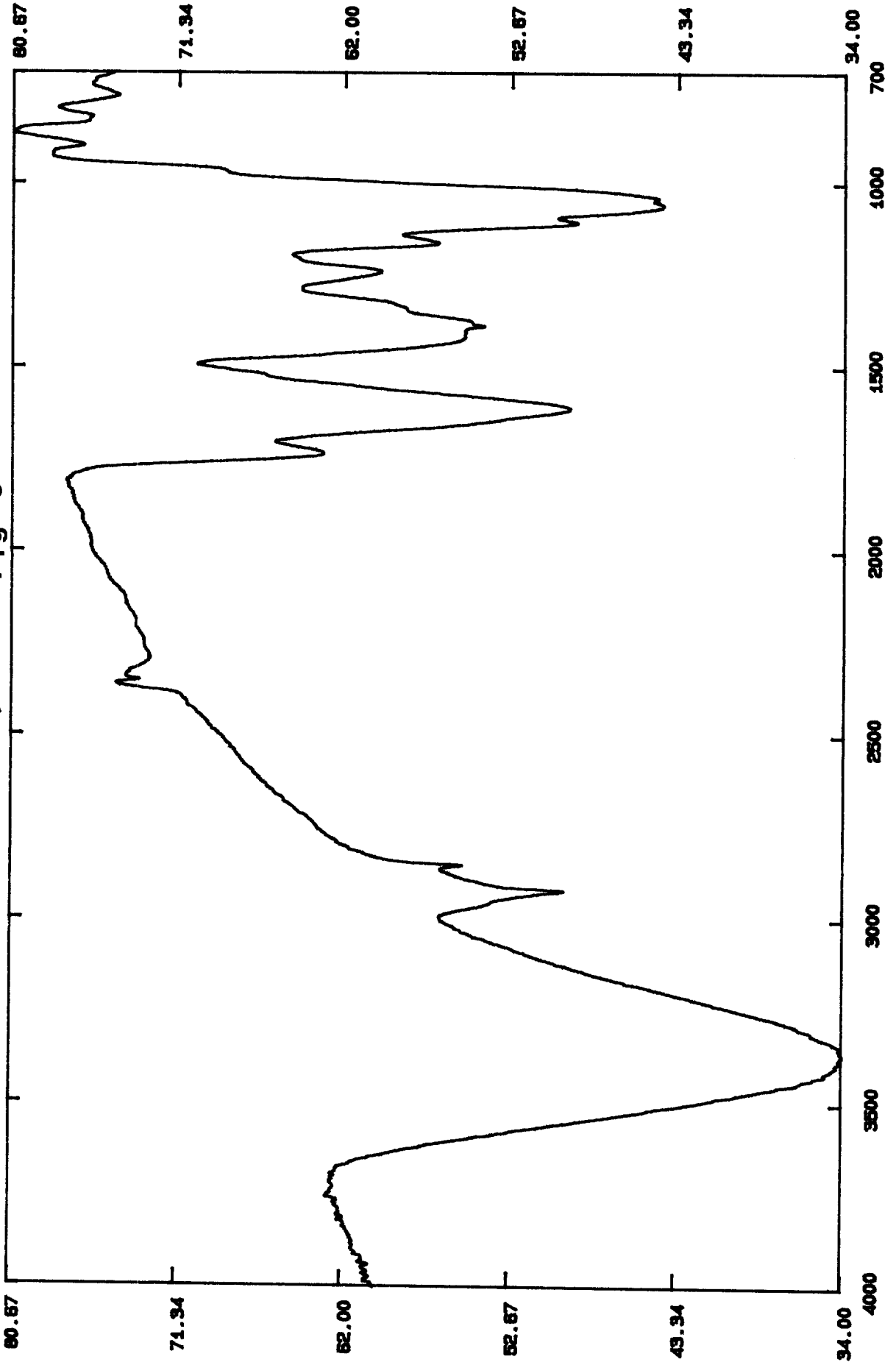

Henna (black powder) Fig 10

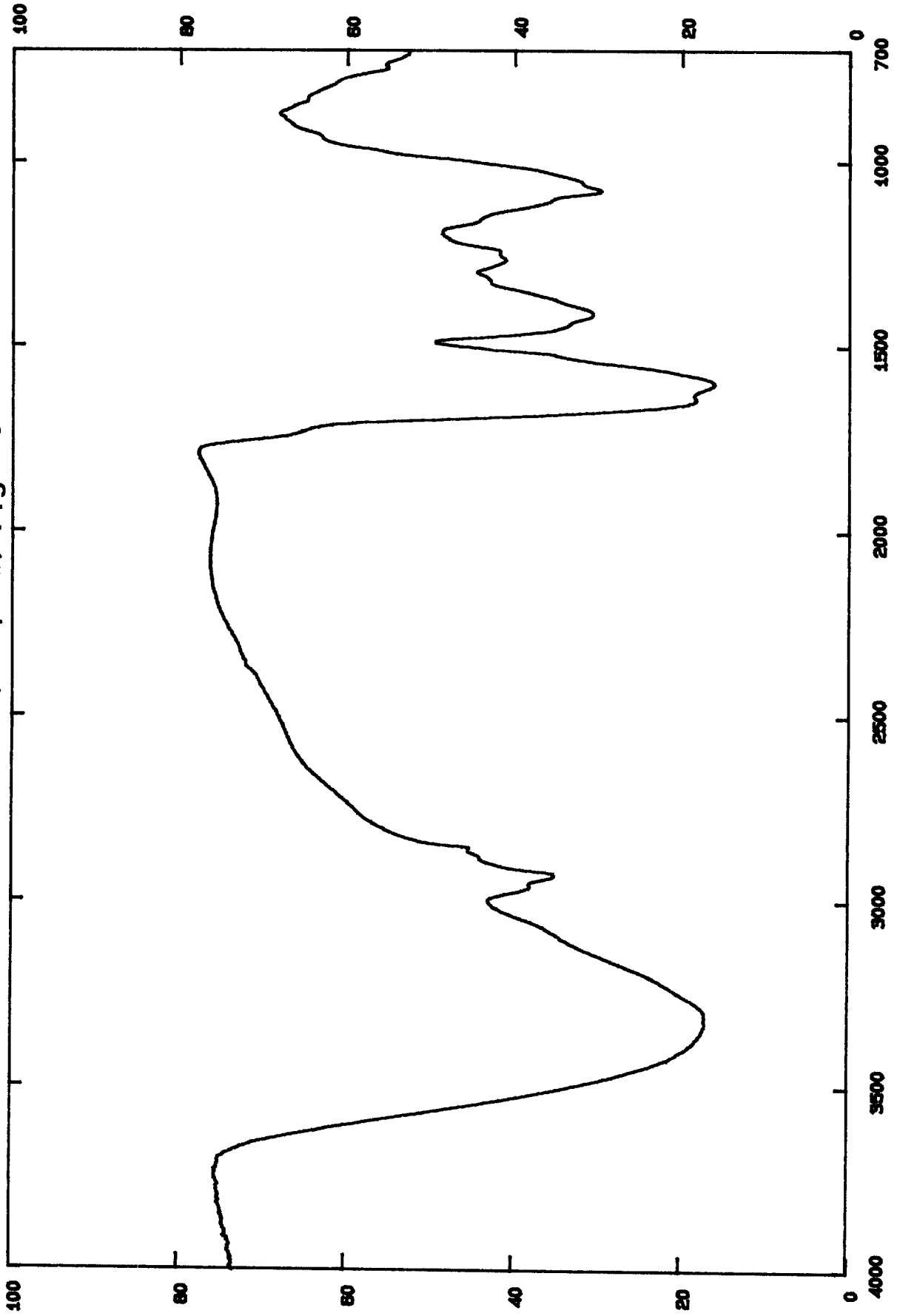

Goldenrod Fig 11

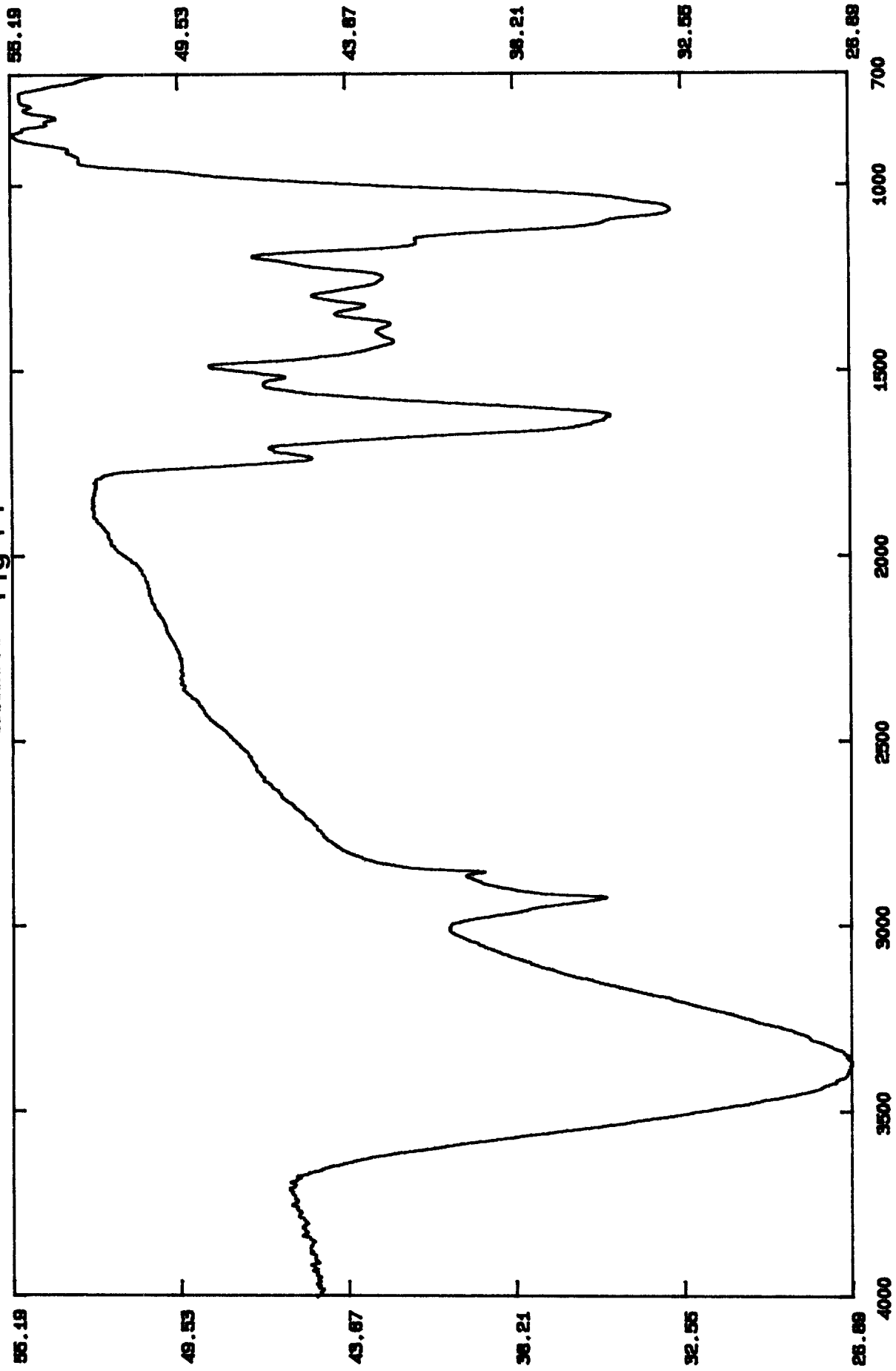

Catechu (powder) Fig 12

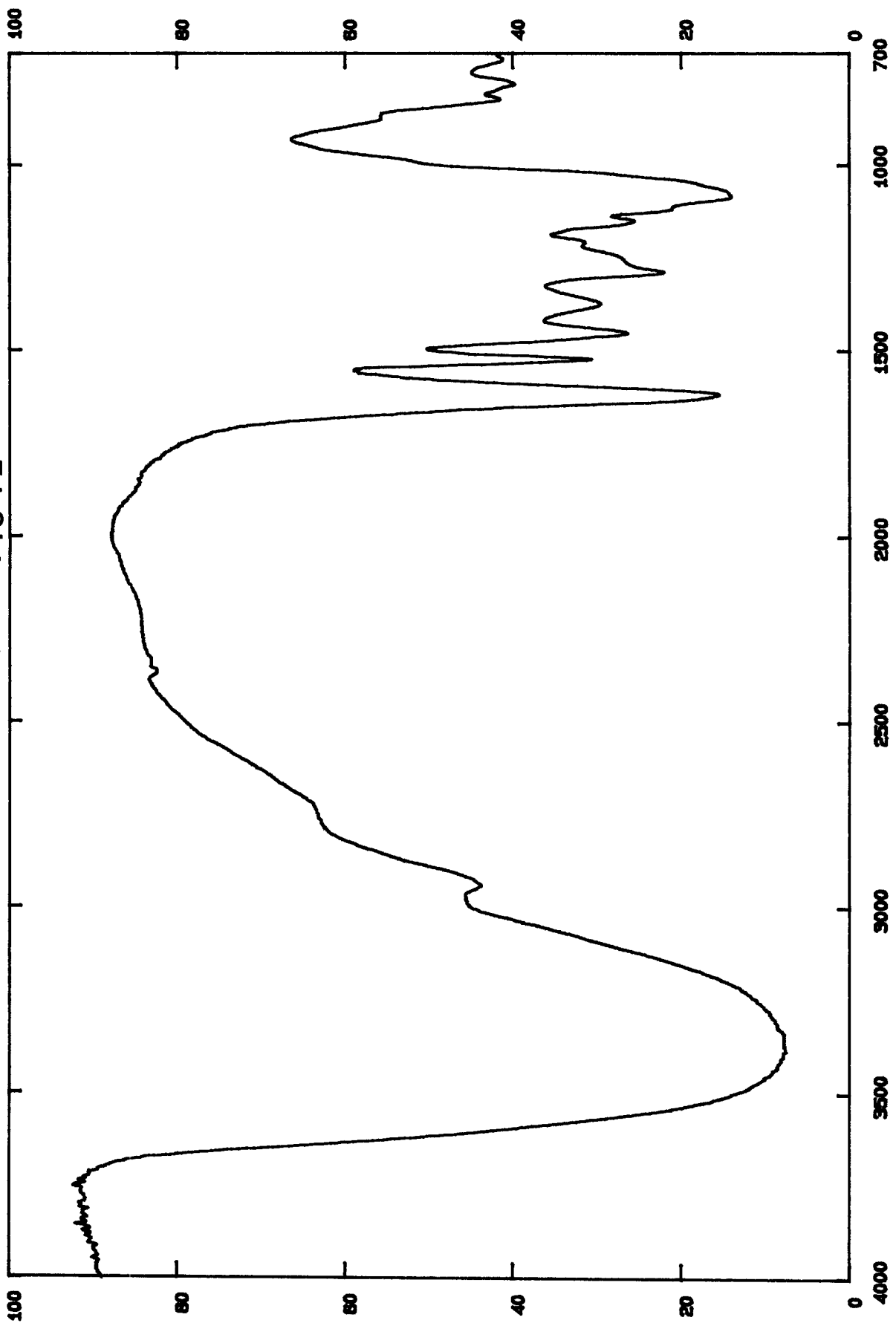

Irish Moss Fig 13

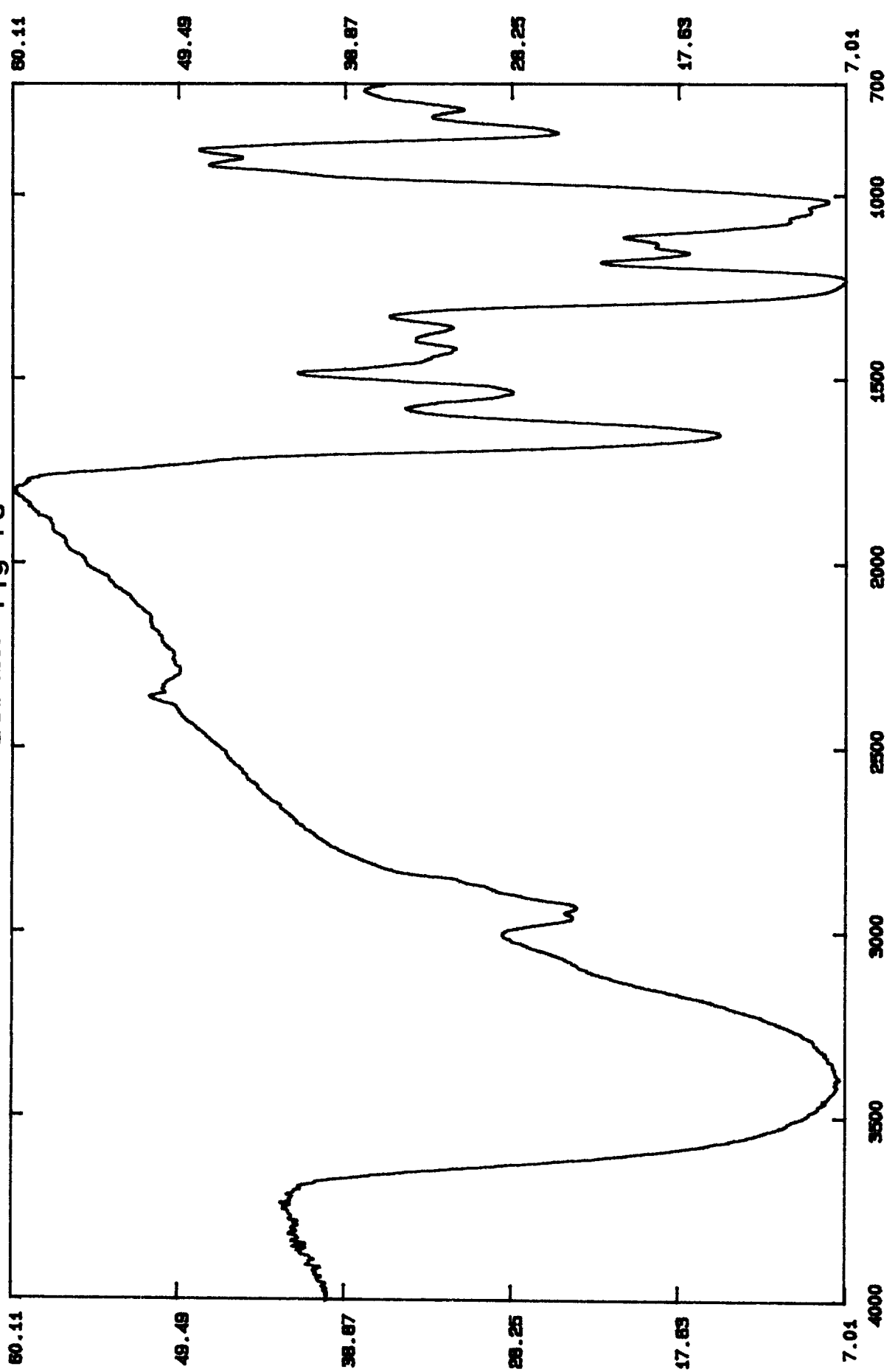

Frenguelae Cortex Fig 14

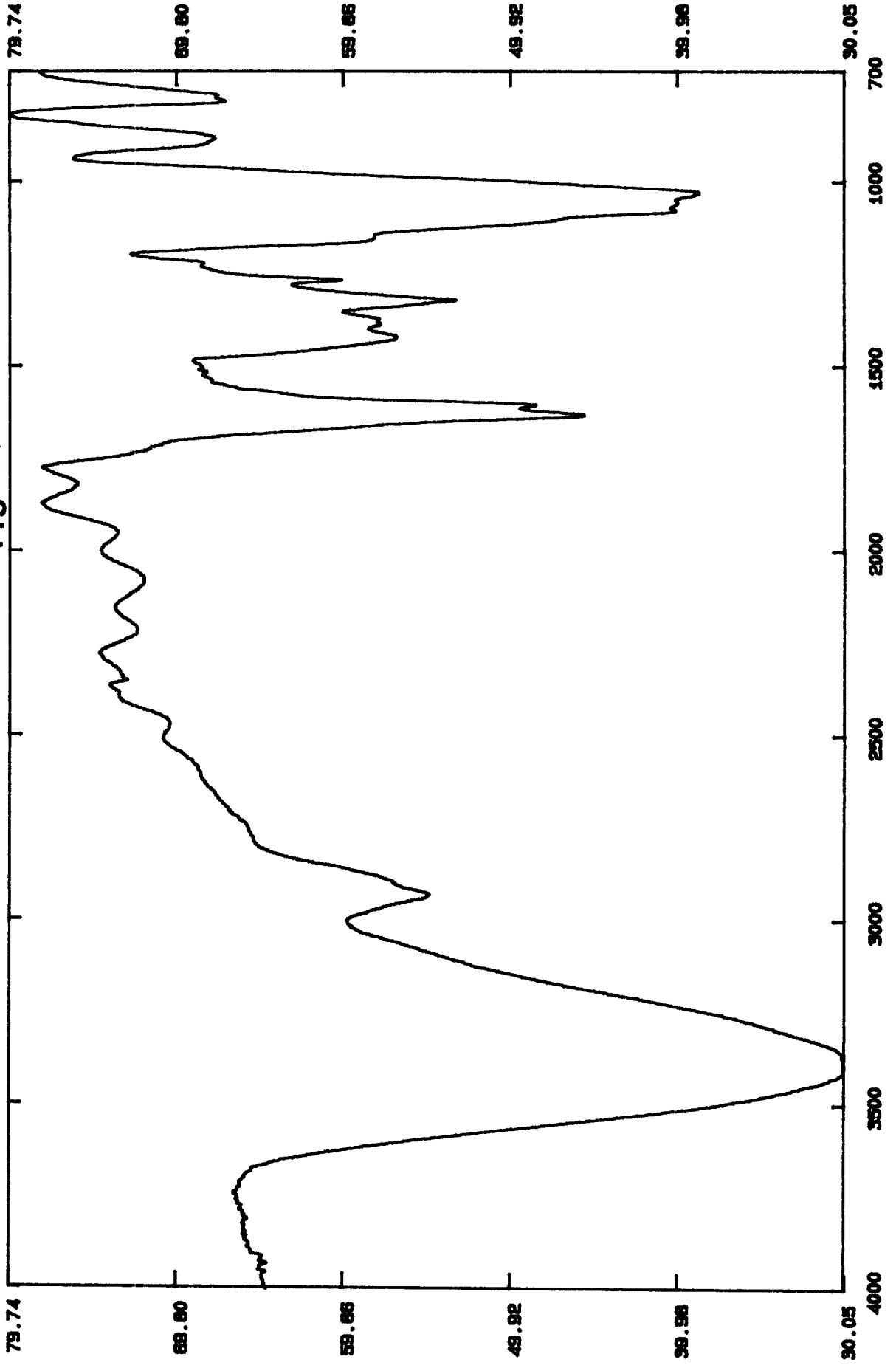

Caseel Brown, for staining wood (H2O soluble) Fig 15

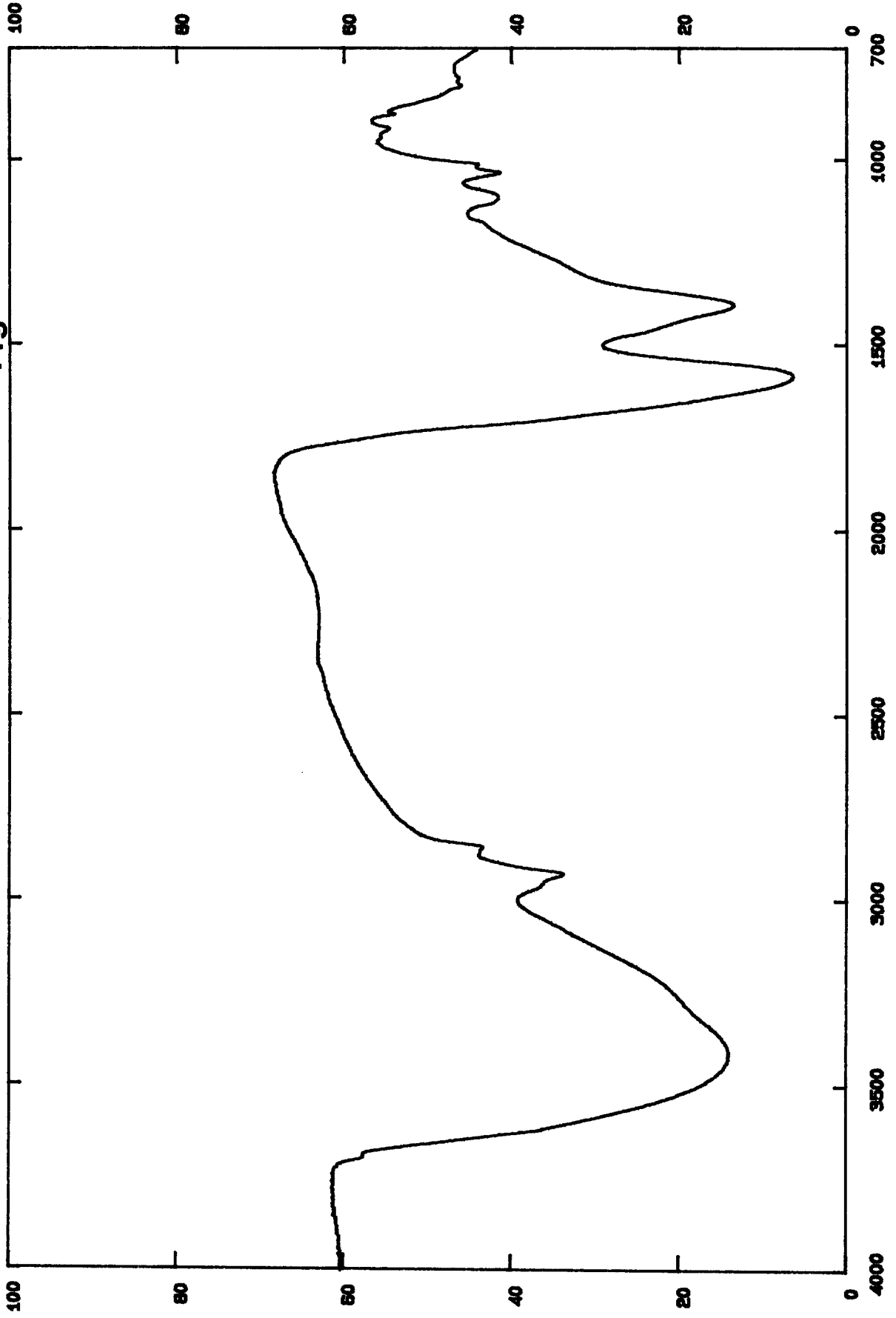

Red Jasper Fig 16

