

GROCERY BAG KITE

1. Cut out the whole bottom of the paper bag. Leave just a paper tube.
2. Draw a line 6 inches from each edge in the middle, along the seam.
3. Cut out along the line and open the bag flat.
4. Fold the sides in half long ways.
5. Tape the front of the bag to the fold on the back of the bag, making the bag sides into "wings".

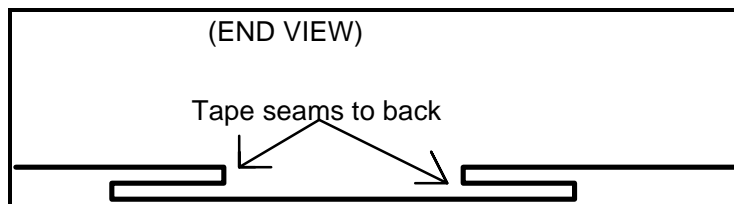
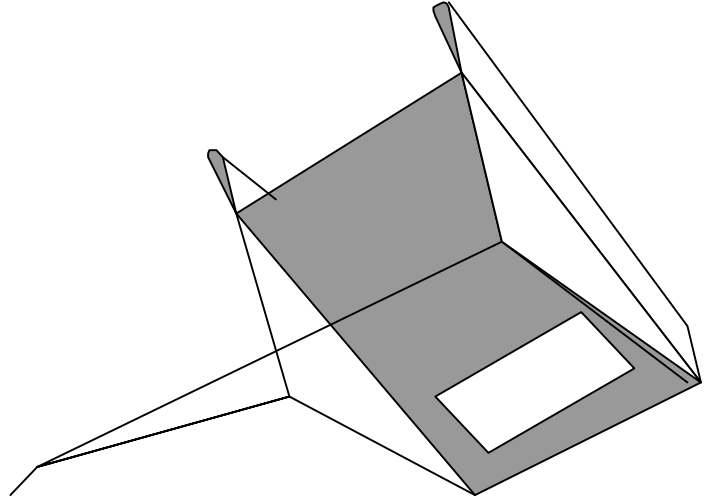

6. On the front flaps mark 5 inches down and draw a line from the top corners to the mark, also draw a line from the bottom corner to the marks.
7. Cut along the lines.

8. Cut out a vent hole in the bottom of the main panel. Make the vent 4 inches tall and 8 inches wide (2 inches up from the bottom and 2 inches from each side).
9. Put tape over the points of the front panels and punch holes for the string.
10. Tie a 6 foot length of string into the holes on the front panel flaps and make a loop at the center of the string for a bridle.
11. Attach string to the bridle and fly your kite.
12. Have fun.

